

**MILAN**  
**87"x62" - PANEL DETAIL**  
 Unscaled

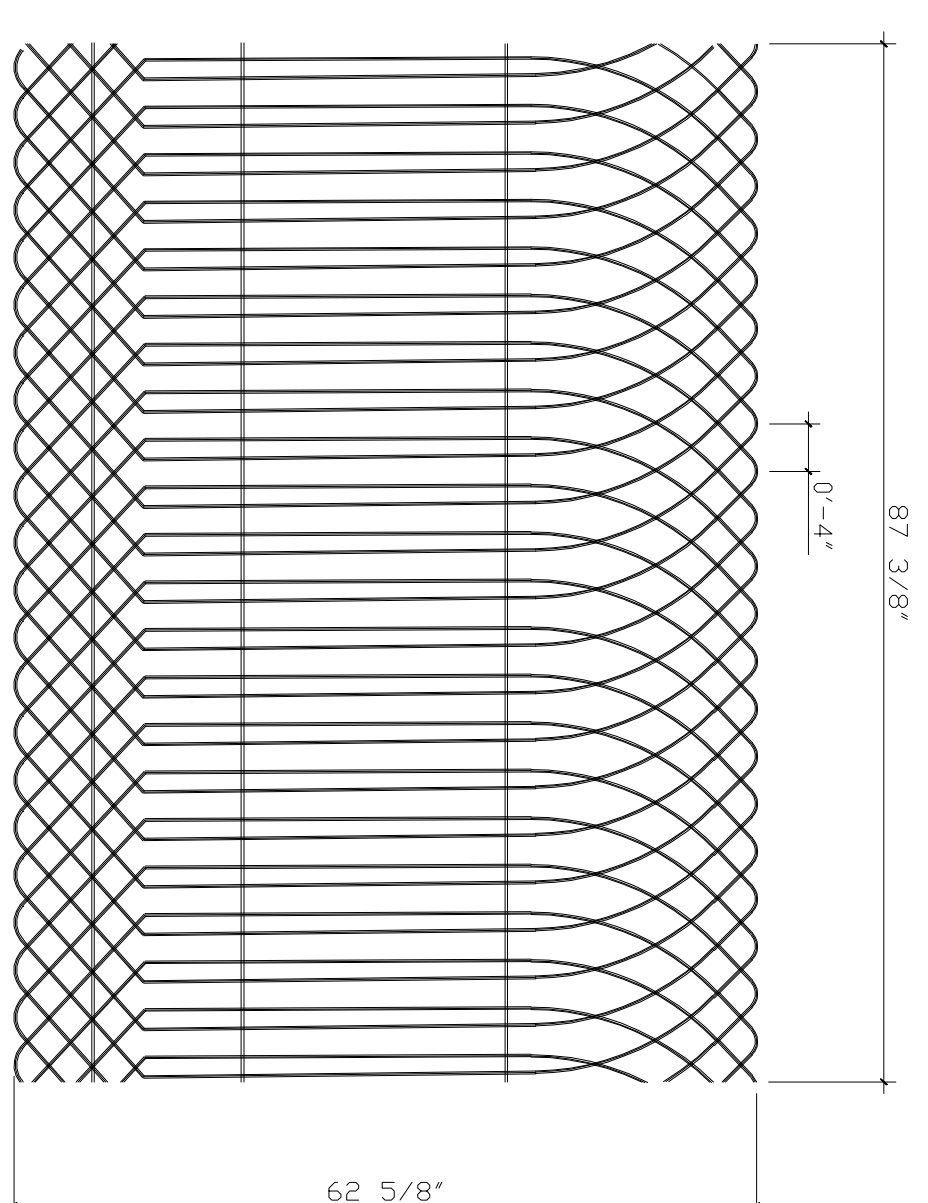

DMF FLORENCE PANEL SPECIFICATIONS		
SPECIFICATION	TOLERANCE	NOTES
HORIZONTAL WIRE	±0.0019" / ±0.05mm	
FORMING WIRE	4 GA 0.22" ±0.0019" / ±0.05mm	
TENSIONING STRENGTH	80 ksi	
ZINC COATING	32 oz/ft <sup>2</sup>	ASTM A-641
POWDER COATING THICKNESS	TOIC FREE/VOC FREE	100 MICRONS ASTM D-7091

DMF POST SPECIFICATIONS		
DIMENSION	SPECIFICATION	NOTES
POST SIZE	62mm(2.44")	ALLOY 6063 T5 ASTM B-221
POST GAUGE	0.059"	ALLOY 6063 T5
POST CAP	PLASTIC INJECTION	POLYPROPYLENE
HARDWARE CLAMPS	STAINLESS STEEL	
POWDER COATING THICKNESS	100 MICRONS	TOIC FREE/VOC FREE ASTM D-7091

**MILAN**  
**87"x62" - INSTALLATION DETAIL**  
 Unscaled

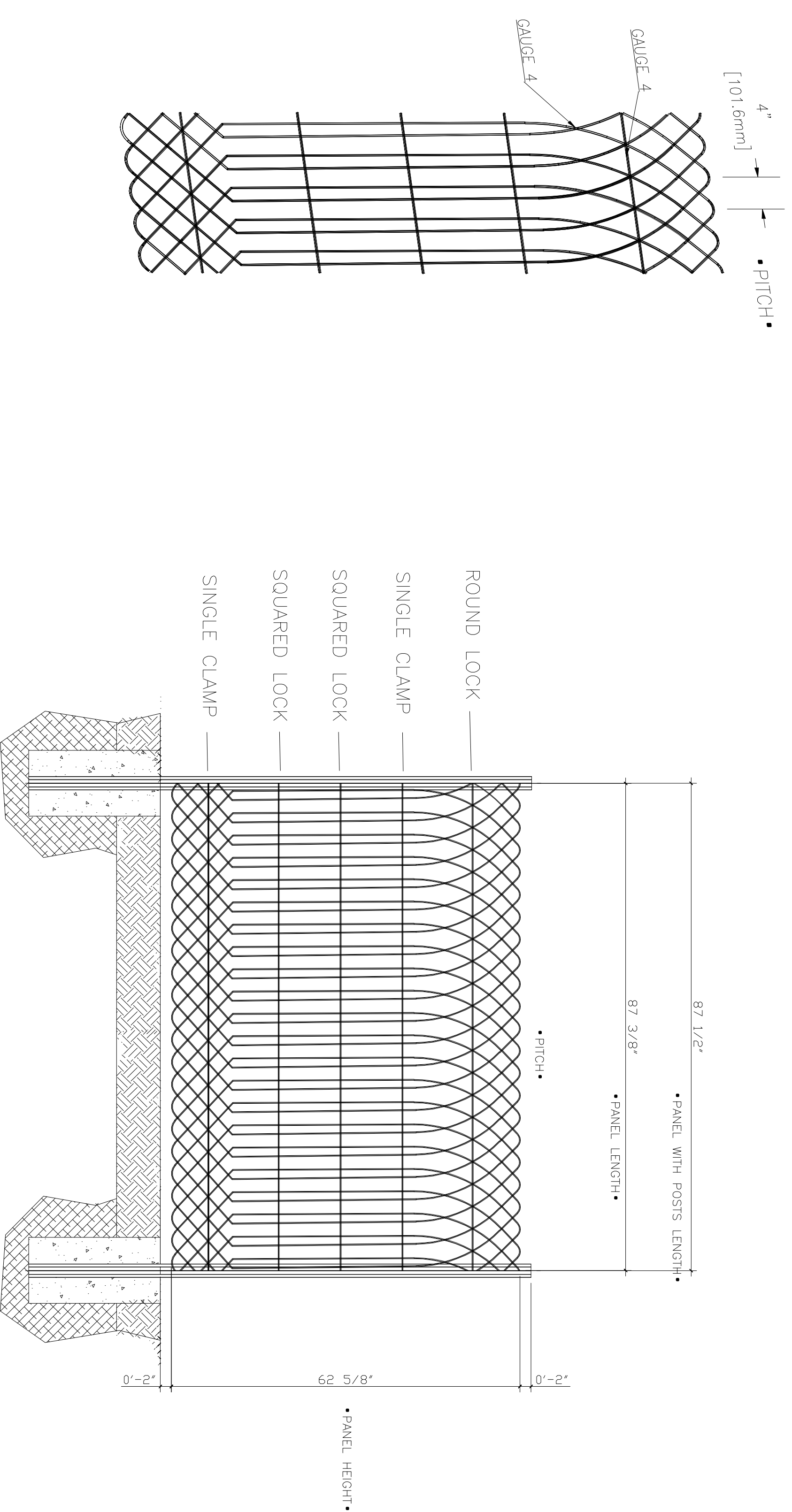

**MILAN**  
**87"x62" - SIDE VIEW**  
 Unscaled

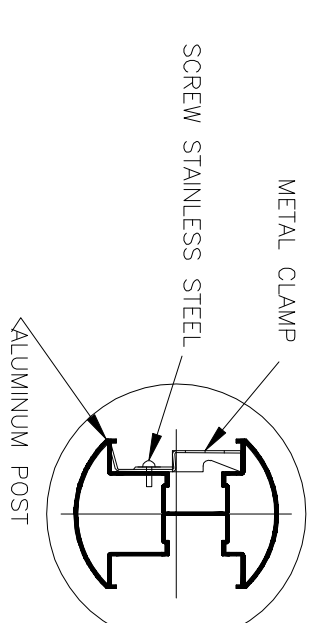
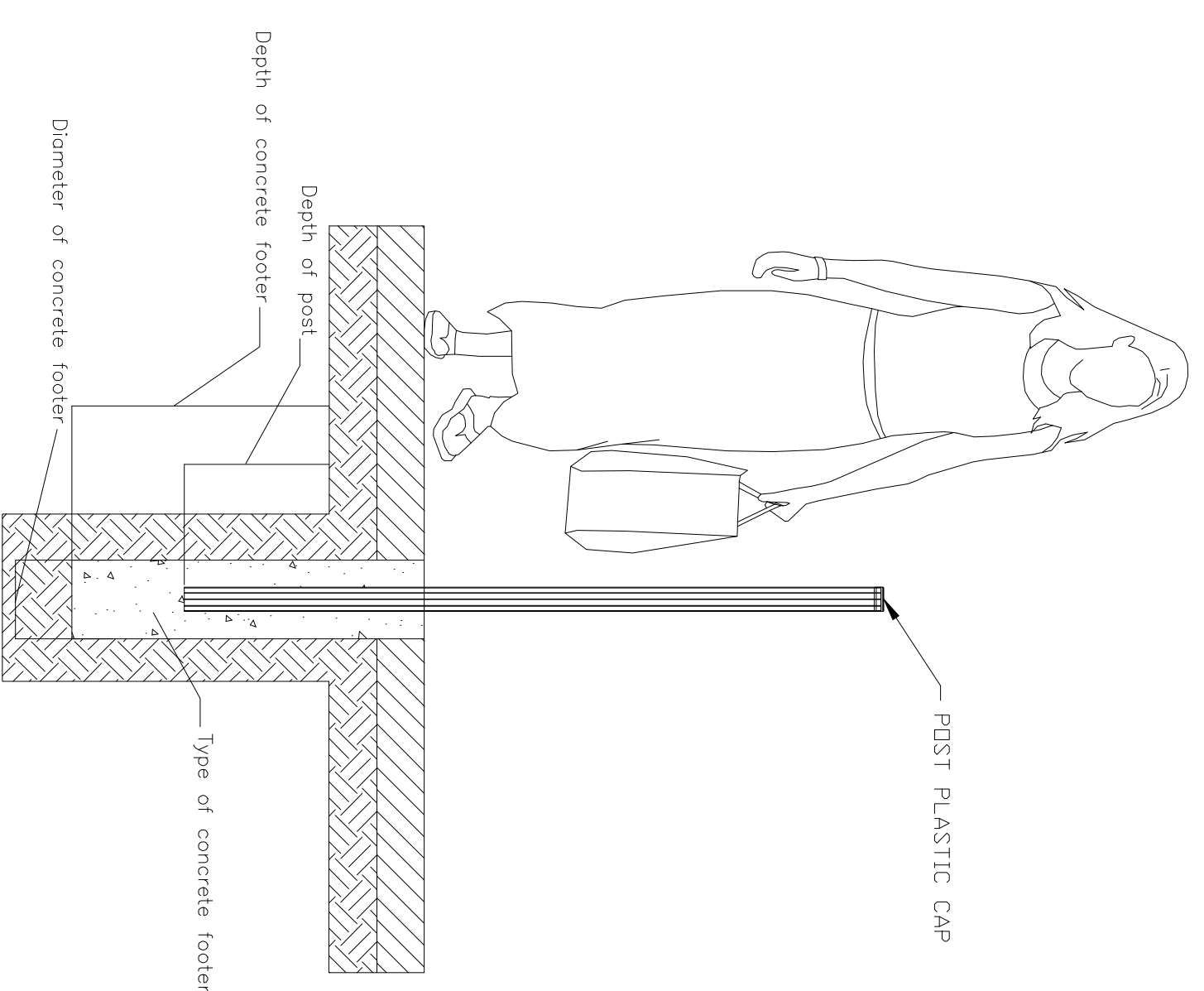

DRAWINGS BY:  
 VP & ASSOCIATES, INC.  
 206 S. FEND ST.  
 TAMPA, FL 33605  
 PH: 813-247-3835  
 FAX: 813-247-4305

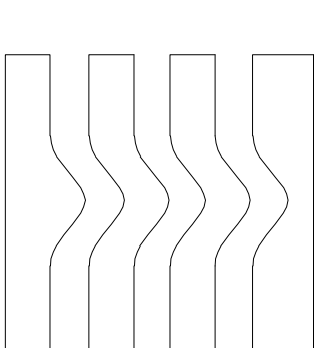

**Designmaster™**  
 FENCING SYSTEM

DMF – MILAN 62”  
 SPECIFICATIONS

PROJECT NAME:	GENERAL SPECS
CUSTOMER:	DESIGN MASTER FENCE
DATE: JANUARY, 2017	